

TECHNICAL INFORMATION

DC003051 Gear box

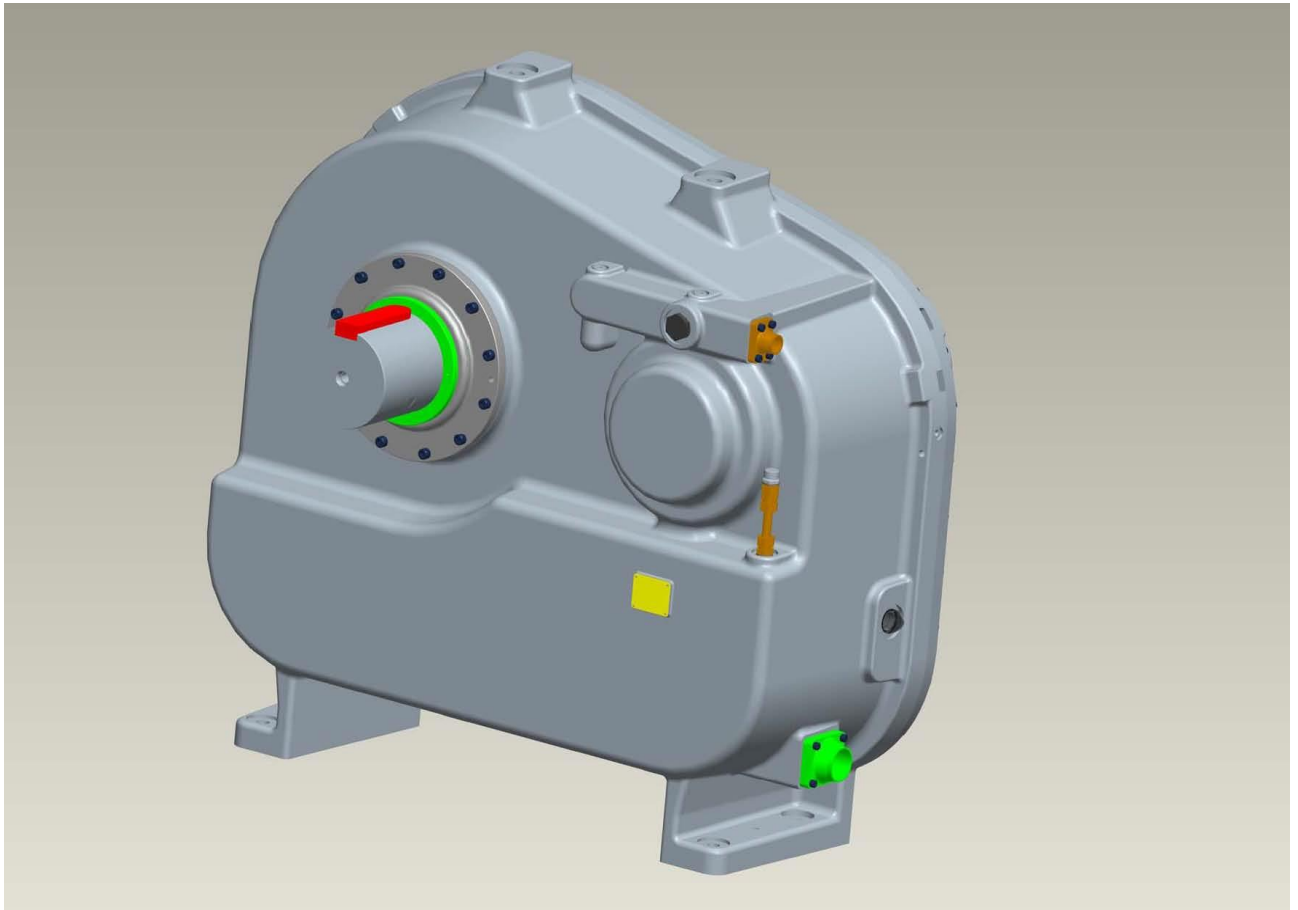

Contents

1. Technical data	page 3
1.1 Specification – Gearbox DC003	
1.2 Description oil system	
2. Installation	page 4
2.1 Functional description	
2.2 Transport and handling	
2.3 Lubrication oil system	
2.4 Checklist before initial start up	page 5
3. Start up and operational instructions	page 6
3.1 Start up and shut down procedure	
3.2 Safety aspects of running the DC003	
4. Maintenance	page 9
4.1 Service general	
4.2 External oil system	
4.3 Spare parts	
5. Documentation	page 10
5.1 Installation of coupling	
5.2 Drawing: DC003051	

1. Technical data

1.1 Specification Gearbox DC003051

Layout:	A Gearbox for 2800 kW power.
Drive configuration:	Drive shaft A, max 2500 rpm, Shaft B 1500 rpm. Ratio: 1.67:1
Dimensions:	LxWxH: 883x1269x1192 mm (excl couplings)
Weight:	1640 kg (excl couplings)
Ambient temp:	-20°C to +80°C
Orientation of Gearbox:	According to layout drawing "DC003051 sheet1".
Material in housing:	Cast iron SS0125
Material in gears:	Steel

1.2 Description oil system

Lubrication system:	Circulating oil system.
Oil blocking system:	Lip sealing package on all shaft ends
Oil pressure:	4.5 Bar abs
Oil flow:	60 L min
Oil cooler power requirement:	35 kW min
Oil reservoir volume:	105 L + external devices
Lubrication oil type:	Statoil Mereta 68 or similar
Oil temp. injected:	-5°C to +80°C; Recommended +40°C to +60°C
Oil filter requirement:	15µm
Max pressure drop in cooler:	0.3 Bar
Pressure gage:	Recommended to indicate pressure below 2 Bar abs at injection point.

2. Installation

2.1 Functional description

The Gearbox DC003 used to connect expander/compressor with generator/motor. Between the units couplings will be used. The DC003 have one internal oil tank and over flow valve but not any oil cooler or pump. For that reason DC003 have two connections oil outlet and oil inlet, se Drawing DC003051.

2.2 Transportation and handling

Please take the following precautions when transporting and handling the DC003 during installation:

- The DC003 must be transported standing fixed with mounting feet. The Lifting eyes shall be used when the DC003 needs to be lifted.

The lifting lugs on the Gearbox can **only** be used to lifting the Gearbox DC003 and not any other units or frames.

- Always cover the DC003 connections in order to prevent water, dust and debris to enter the DC003 and cause damage.
- Do NOT remove the protective covers from the connections until the expander is mounted in place and the oil piping will be fitted.

2.3 Lubrication oil system

Please acknowledge the following instructions and warnings to avoid injury.

An external oil cooler system is required in order to ensure proper operation of gears, drive shaft seal and bearings. DC003 have two connections “oil outlet” and “oil inlet”. The position of this connections, see picture 3.2.2 and drawing on page 11

The following functions are essential:

- Oil cooler
- Oil pressure guard (recommended)
- Oil temperature guard
- Oil filter
- Oil pump

The Gearbox DC003 has following components integrated:

- Oil sump being vented to atmosphere
- Over flow valve for specified pressure

2.4 Checklist before initial start up

Please acknowledge the following checklist before attempting to start up the DC003:

- 1 Check the oil level in the oil sump, of 105 litres +external pipes and cooler.
- 2 Check that it is oil in cooler and pipes.
- 3 Check that the oil connections are correctly and properly secured.
See picture 3.2.2
- 4 Check that all couplings are correctly and properly mounted and assembled.
See picture 3.2.3

3. Start up and operational instructions

3.1 Start up and shut down procedure

- Prime the pump with oil before start if DC003 have been stationary for > 1 month.
- Oil pressure is to be applied immediately after the DC003 is started.
- The acceleration up to nominal speed should be swift without unnecessary delay.
- Do not run continuously at operating speeds below 1000 rpm on shaft A.
- Check the oil pressure at inlets of the DC003 immediately after start up.
- Please inspect the DC003 and the oil system after the first test run and check for oil leakages.
- When the oil pressure is removed the unit must be stopped without delay.
- **Do not operate DC003 without applied oil pressure!**
- Max allowed operating speed is 2500 rpm for shaft A

3.2 Safety aspects of running the Gearbox DC003

Please acknowledge the following instructions and warnings to avoid injury.

- Hot surfaces: Make sure that appropriate precautions are taken to avoid any kind of injuries related to contact with hot surfaces. The surface temperature of the DC003 stage may exceed 80°C during operation and will stay warm for a long period after the DC003 has been stopped.
- Noise: Make sure that appropriate precautions are taken to avoid any kind of injuries related to the noise generated by the DC002. Exposure to the noise levels from the DC003 without wearing noise protection will result in permanent hearing dysfunction.
- Damage: Always make sure to mount protection covers around the couplings to prevent personal injury.
- Toxic oil: Make sure that appropriate precautions are taken to avoid any unnecessary contact with any oil traces on the DC003 or the lubrication oil system. Use protective gloves at all time.

Picture 3.2.2 Oil connections and information

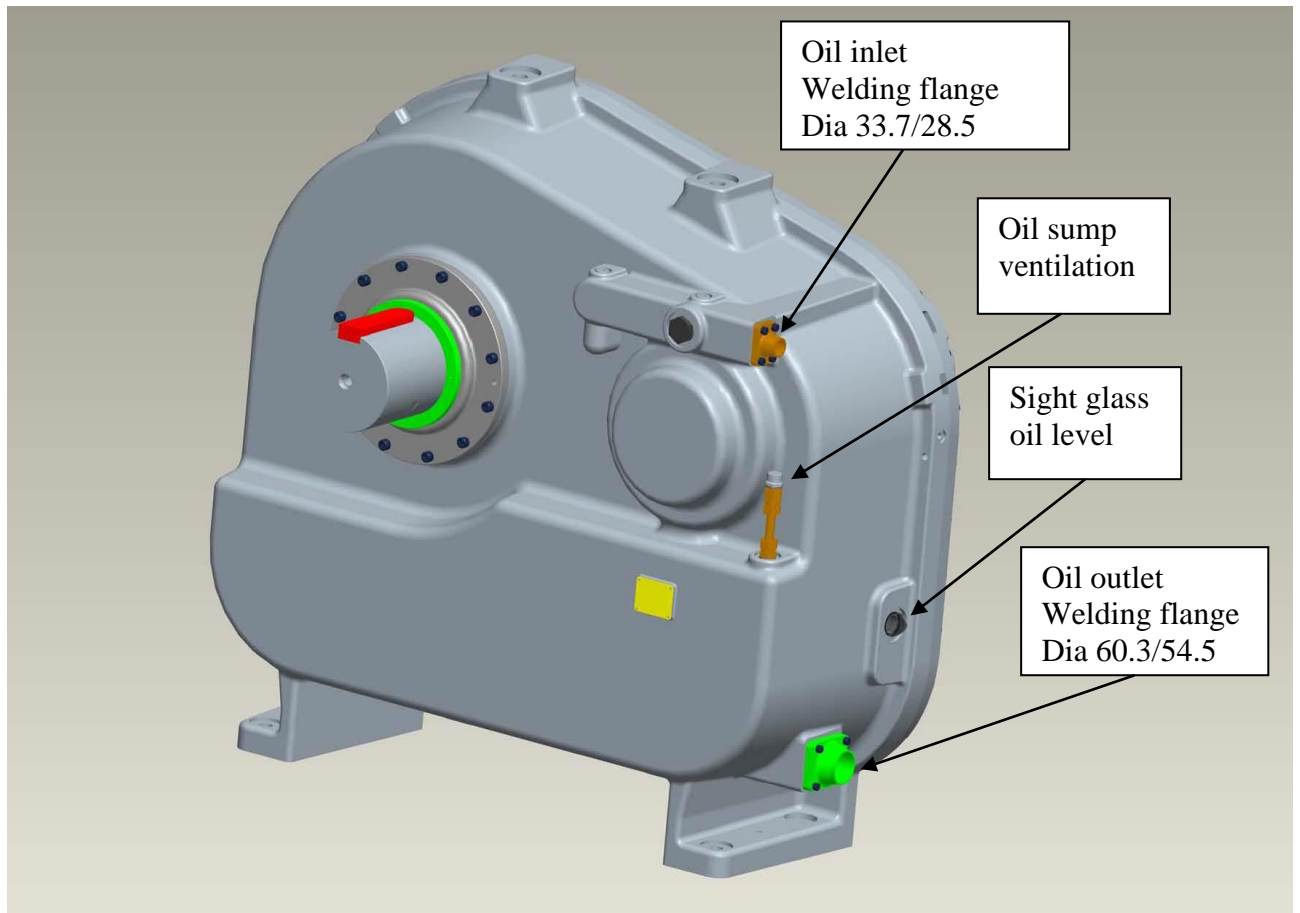

Picture 3.2.3 Gearbox with shafts information

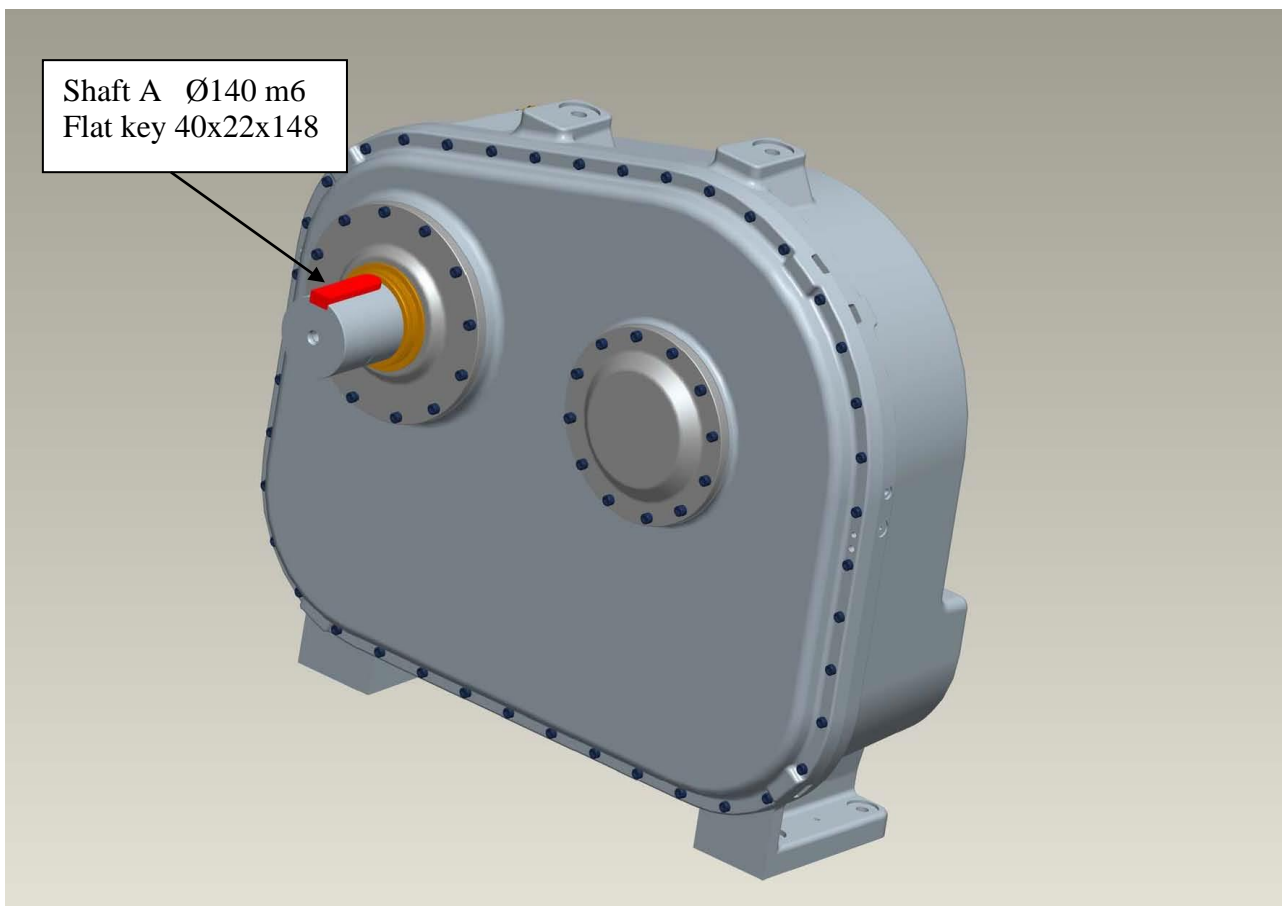
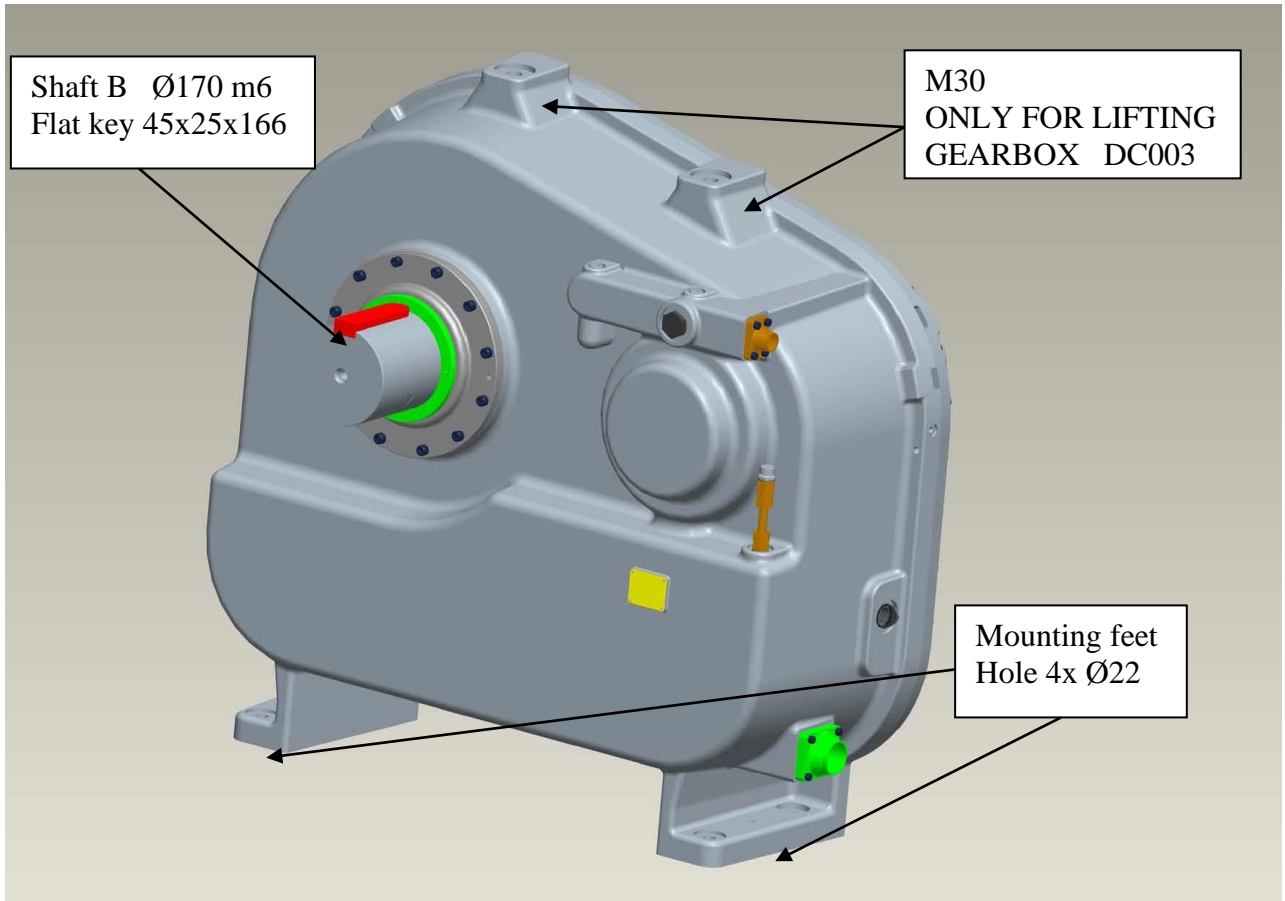

4. Maintenance

4.1 Service general

Please follow the recommendations below:

Service interval:	Gearbox DC003:	Every 17.500 hours or 3 years whichever ever comes first *
-------------------	----------------	---

For service of DC003 change the oil and change oil filter.

* For other service please contact SRM for authorized service personal.

4.2 External oil system

Oil change interval:	OES Responsibility
Filter change interval:	OES Responsibility

4.3 Spare parts

Original spare parts will be provided by SRM's authorized service personal.

5. Documentation

5.1 Installation of coupling

The couplings for Gearbox DC003 are designed for key shaft and locking screws.

Move the unit (Expander/Generator) to line the shaft, see separate document for the coupling.

The distance between the two coupling parts on shafts shall have enough space for mounting the spacer.

There is not any place reserved for speed sensor on gearbox.

Line the shafts before mounting the couplings.

NOTE! Positions marked as “Not included” are not included in DC003 package.

The couplings must be order separately.

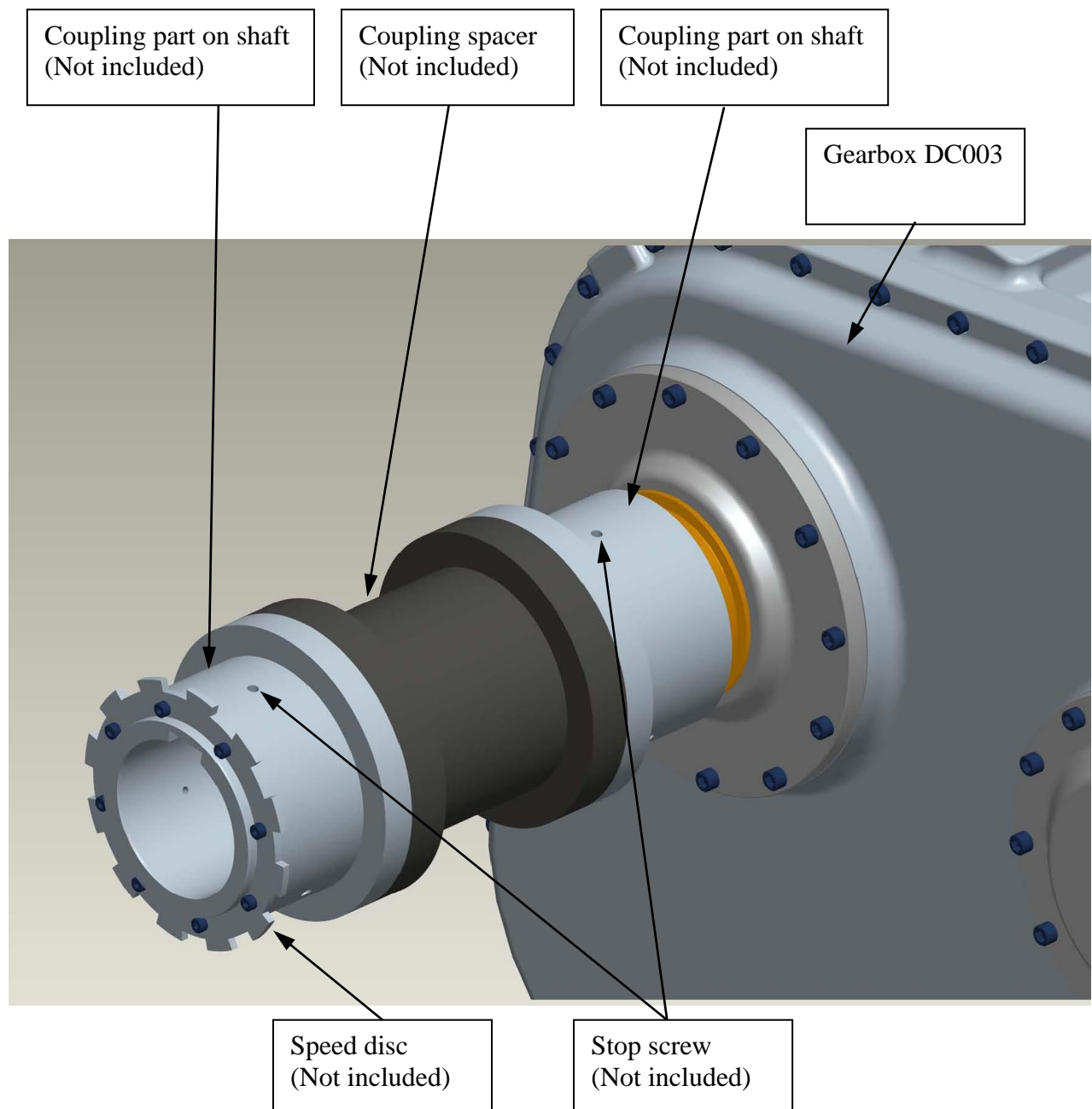

5.2 Drawing DC003051

